

**CHICAGO POWER  
ELECTRIC® SYSTEMS**

# **AUTOMATIC BATTERY CHARGER**

**Model 93781**

## **ASSEMBLY & OPERATING INSTRUCTIONS**



Due to continuing improvements, actual product may differ slightly from the product described herein.

Distributed exclusively by  
Harbor Freight Tools®.

3491 Mission Oaks Blvd., Camarillo, CA 93011  
Visit our Web site at <http://www.harborfreight.com>

**TO PREVENT SERIOUS INJURY,  
READ AND UNDERSTAND ALL WARNINGS  
AND INSTRUCTIONS BEFORE USE.**

Copyright© 2005 by Harbor Freight Tools®. All rights reserved. No portion of this manual or any artwork contained herein may be reproduced in any shape or form without the express written consent of Harbor Freight Tools.

**For technical questions and replacement parts, please call 1-800-444-3353.**

THANK YOU for choosing a **HARBOR FREIGHT TOOLS** product. For future reference, please complete the owner's record below:

**Model** \_\_\_\_\_ **Serial No.** \_\_\_\_\_ **Purchase Date** \_\_\_\_\_

SAVE THE RECEIPT, WARRANTY AND THESE INSTRUCTIONS. It is important that you read the entire manual to become familiar with the unit BEFORE you begin assembly.

### Technical Specifications

Input Voltage:	115V
Output Voltage:	13.5V
Charging Current:	1.1 Amps
Battery Cables:	6 Foot long
Overall Dimensions:	3-1/2" W X 6-5/8" L X 7" H
Power Cord:	18 Gauge X 2 Wire UL <sup>®</sup> listed
Net Weight:	2.5 Lbs.
Automatic charging:	Battery Charger will not overcharge.
Multiple LED indicator lights:	Red LED (on left) = reversed polarity, Red LED (center) = "charging" mode, Green LED (on right) = fully charged – trickle charge mode.

**For best results, the capacity of the battery should be below 24 Ah.**



***READ ALL INSTRUCTIONS BEFORE USING THIS PRODUCT!***

### **Safety Warnings and Precautions**

**WARNING:** When using product, basic safety precautions should always be followed to reduce the risk of personal injury and damage to equipment.

**Read all instructions before using this product!**

#### **WORK AREA**

1. **Keep your work area clean and well lit.** Cluttered benches and dark areas invite accidents.
2. **Do not operate the Battery Charger in explosive atmospheres, such as in the presence of flammable liquids, gases, or dust.** Electrical products create sparks which may ignite the dust or fumes.
3. **Keep bystanders, children, and visitors away while operating the Battery Charger.** Distractions can cause you to lose control. Protect others in the work area from sparks. Provide barriers or shields as needed.

#### **ELECTRICAL SAFETY**

4. **Grounded products must be plugged into an outlet properly installed and grounded in accordance with all codes and ordinances. Never remove the grounding prong or modify the plug in any way. Do not use any adapter plugs. Check with a qualified electrician if you are in doubt as to whether the outlet is properly grounded.** If a grounded product should electrically malfunction or break down, grounding provides a low resistance path to carry electricity away from the user.

5. **Double insulated products are equipped with a polarized plug (one blade is wider than the other). This plug will fit in a polarized outlet only one way. If the plug does not fit fully in the outlet, reverse the plug. If it still does not fit, contact a qualified electrician to install a polarized outlet. Do not change the plug in any way.** Double insulation  eliminates the need for the three wire grounded power cord and grounded power supply system.
6. **Avoid body contact with grounded surfaces such as pipes, radiators, ranges, and refrigerators.** There is an increased risk of electric shock if your body is grounded.
7. **Do not abuse the Power Cord. Never use the Power Cord to carry the Battery Charger or pull the Plug from an outlet. Keep the Power Cord away from heat, oil, sharp edges, or moving parts. Replace damaged Power Cords immediately.** Damaged Power Cords increase the risk of electric shock.
8. **When operating a power tool outside, use an outdoor extension cord marked “W-A” or “W”.** These extension cords are rated for outdoor use, and reduce the risk of electric shock.

#### PERSONAL SAFETY

9. **Stay alert. Watch what you are doing, and use common sense when operating the Battery Charger. Do not operate the Battery Charger while tired or under the influence of drugs, alcohol, or medication.**
10. **Dress properly. Do not wear loose clothing or jewelry. Contain long hair. Keep your hair and clothing away from the Battery Charger.** Loose clothes, jewelry, or long hair can be caught in the Battery Charger, causing personal injury.
11. **Use safety equipment. Always wear eye protection during assembly, use, and maintenance.**

#### TOOL USE AND CARE

12. **Do not overload the Battery Charger. Use the correct Battery Charger for your application.** The Battery Charger will do the job better and safer at the speed and capacity for which it is designed.
13. **Disconnect the Power Cord Plug from the power source before making any adjustments, changing accessories, or storing the Battery Charger.** Such preventive safety measures reduce the risk of turning on the product accidentally.
14. **Store idle tools out of reach of children and other untrained persons.** The Battery Charger is dangerous in the hands of untrained users.
15. **Maintain the Battery Charger with care.** Do not use a damaged Battery Charger. Tag damaged Battery Charger “Do not use” until repaired.

#### SERVICE

16. **Battery Charger service must be performed only by qualified repair personnel.** Service or maintenance performed by unqualified personnel could result in a risk of injury.

## SERVICE (Cont'd)

17. **When servicing the Battery Charger, use only identical replacement parts.** Use of unauthorized parts or failure to follow maintenance instructions may create a risk of electric shock or injury.
18. **Always unplug the Battery Charger from its electrical outlet before performing any inspection, maintenance, or cleaning procedures.**
19. **WARNING! People with pacemakers should consult their physician(s) before using this product. Operation of electrical equipment in close proximity to a heart pacemaker could cause interference or failure of the pacemaker.**
20. **Do not expose the Battery Charger equipment to rain or wet conditions.** Water entering electrically powered equipment will increase the risk of electric shock.

## GROUNDING

### WARNING!

Improperly connecting the grounding wire can result in the risk of electric shock. Check with a qualified electrician if you are in doubt as to whether the outlet is properly grounded. Do not modify the power cord plug provided with the Battery Charger. Never remove the grounding prong from the plug. Do not use the Battery Charger if the power cord or plug is damaged. If damaged, have it repaired by a service facility before use. If the plug will not fit the outlet, have a proper outlet installed by a qualified electrician.

### GROUNDED TOOLS: TOOLS WITH THREE PRONG PLUGS

1. Tools marked with "Grounding Required" have a three wire cord and three prong grounding plug. The plug must be connected to a properly grounded outlet. If the Battery Charger should electrically malfunction or break down, grounding provides a low resistance path to carry electricity away from the user, reducing the risk of electric shock. **(See Figure A.)**
2. The grounding prong in the plug is connected through the green wire inside the cord to the grounding system in the tool. The green wire in the cord must be the only wire connected to the Battery Charger's grounding system and must never be attached to an electrically "live" terminal. **(See Figure A.)**
3. A grounded appliance must be plugged into an appropriate outlet, properly installed and grounded in accordance with all codes and ordinances. The plug and outlet should look like those in the following illustration. **(See Figure A.)**

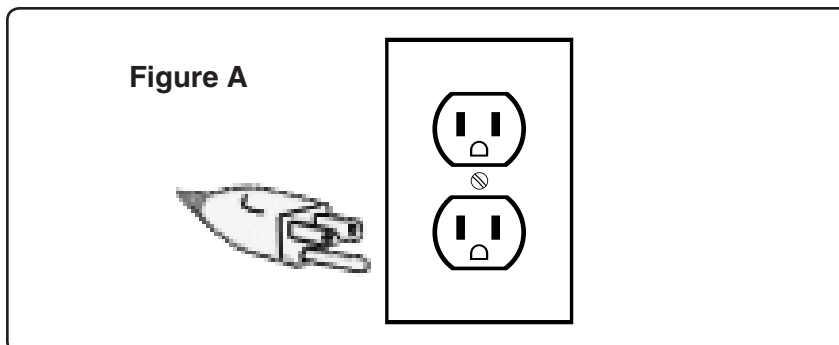

## DOUBLE INSULATED APPLIANCES: APPLIANCES WITH TWO PRONG PLUGS

**Note: The Battery Charger has a Two Prong Plug.**

1. Appliances marked “Double Insulated” do not require grounding. They have a special double insulation system which satisfies OSHA requirements and complies with the applicable standards of Underwriters Laboratories, Inc., the Canadian Standard Association, and the National Electrical Code. **(See Figure B.)**
2. Double insulated tools may be used in either of the 120 volt outlets shown in the following illustration. **(See Figure B.)**

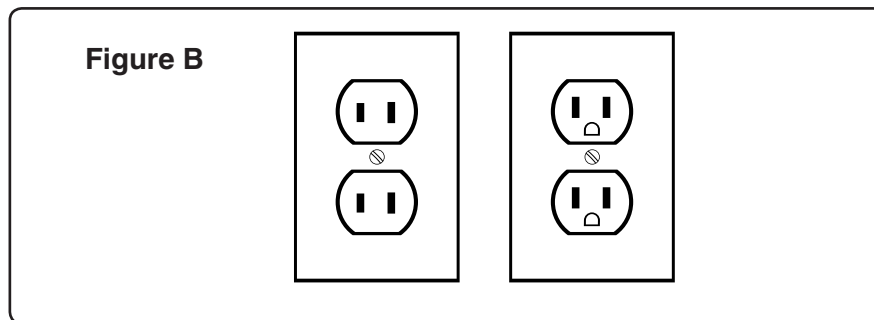

### EXTENSION CORDS

1. **Grounded** appliances require a three wire extension cord. **Double Insulated** products can use either a two or three wire extension cord.
2. As the distance from the supply outlet increases, you must use a heavier gauge extension cord. Using extension cords with inadequately sized wire causes a serious drop in voltage, resulting in loss of power and possible tool damage. **(See Figure C, next page.)**
3. The smaller the gauge number of the wire, the greater the capacity of the cord. For example, a 14 gauge cord can carry a higher current than a 16 gauge cord. **(See Figure C.)**
4. When using more than one extension cord to make up the total length, make sure each cord contains at least the minimum wire size required. **(See Figure C.)**
5. If you are using one extension cord for more than one tool, add the nameplate amperes and use the sum to determine the required minimum cord size. **(See Figure C.)**
6. If you are using an extension cord outdoors, make sure it is marked with the suffix “W-A” (“W” in Canada) to indicate it is acceptable for outdoor use.
7. Make sure your extension cord is properly wired and in good electrical condition. Always replace a damaged extension cord or have it repaired by a qualified electrician before using it.
8. Protect your extension cords from sharp objects, excessive heat, and damp or wet areas.

RECOMMENDED MINIMUM WIRE GAUGE FOR EXTENSION CORDS*					
NAMEPLATE AMPERES (At Full Load)	EXTENSION CORD LENGTH				
	25 Feet	50 Feet	75 Feet	100 Feet	150 Feet
0 - 2.0	18	18	18	18	16
2.1 - 3.4	18	18	18	16	14
3.5 - 5.0	18	18	16	14	12
5.1 - 7.0	18	16	14	12	12

**Specific Safety Rules for the Battery Charger**

1. **Maintain labels and nameplates on the Battery Charger.** These carry important information. If the labels are unreadable or missing, contact Harbor Freight Tools for replacement.
2. **Always place the Battery Charger on a dry, flat, level, sturdy nonflammable work surface capable of supporting the weight of the Battery Charger.** Make sure to place the Battery Charger in a location that is out of reach of children.
3. **The Battery Charger is not a toy and should not be used by children.**

**WARNING! Risk of explosive gases:**

1. **Working in the vicinity of lead-acid batteries is dangerous. Batteries generate explosive gases during normal battery operation. For this reason, it is of utmost importance that each time before using this Battery Charger you read and understand all safety warnings and precautions as outlined in this manual and those manuals published by the battery and vehicle manufacturers and manufacturers of any equipment you intend to use in the vicinity of the battery.**

**Personal Precautions:**

1. **ALWAYS wear ANSI approved safety impact eye goggles when working with lead-acid batteries.**
2. **Make sure someone is within range of your voice and close enough to come to your aid when you work near a lead-acid battery.**

3. **Keep plenty of fresh water and soap nearby in case battery acid contacts skin, clothing, or eyes.** Avoid touching eyes while working near a lead-acid battery. If battery acid contacts skin or clothing, wash immediately with soap and water. If acid enters the eyes, immediately flood eyes with running cold water for at least 10 minutes and get medical attention immediately.
4. **NEVER smoke or allow a spark or flame in the vicinity of a lead-acid battery or vehicle engine.**
5. **Use caution to reduce the risk of dropping a metal tool onto a lead-acid battery.** The tool may spark or short circuit the battery or other electrical part that may cause an explosion.
6. **Remove personal metal items such as rings, bracelets, necklaces, and watches when working with a lead-acid battery.** A lead-acid battery can produce a short circuit current high enough to weld a ring or other metal item, causing a severe burn.
7. **Use the Battery Charger for charging lead-acid batteries only.** This Battery Charger is not intended to supply power to a low voltage electrical system other than in a starter motor application. Do not use this Battery Charger for charging dry-cell batteries. Dry-cell batteries may burst and cause serious personal injury and/or property damage. **NEVER charge a frozen battery.**

#### **Preparing To Charge:**

1. **If it is necessary to remove the battery from a vehicle to charge, always remove the grounded terminal from the battery first.** Make sure all accessories in the vehicle are off, so as not to cause an arc.
2. **Make sure the area around the battery is well ventilated while the battery is being charged.**
3. **Clean the battery terminals prior to charging the battery.**
4. **Add distilled water in each cell until the battery acid reaches the level specified by the battery manufacturer.** This helps purge excessive gas from the cells. Do not overfill. For a battery without cell caps, carefully follow the battery manufacturer's recharging instructions.
5. **Determine the voltage of the battery by referring to the vehicle owner's manual, confirm it is 12 volt.**

#### **Charger Location:**

1. **Always locate the Battery Charger as far away from the battery as the Charger's DC cables permit.**
2. **Never place the Battery Charger directly above the battery being charged.** Gases from the battery will corrode and damage the Battery Charger.
3. **Never allow battery acid to drip on the Battery Charger.**

4. Do not operate the Battery Charger in a closed-in area, or restrict ventilation in any way.
5. Do not set a battery on top of the Battery Charger.



**DC Connection Precautions:**

1. Connect and disconnect DC output clamps only after removing the AC power cord from the electrical outlet.
2. Never allow the DC output clamps to touch each other.
3. Attach the DC output clamps to the battery posts and twist or rock the clamps back and forth several times to make a good connection. This helps keep the clamps from slipping off the terminals, and helps to reduce the risk of sparking.

**To Reduce Risk Of Sparking - When The Battery Is In The Vehicle:**

1. Carefully position the AC input and DC output cords to reduce the risk of damage by hood, door, or moving engine parts.
2. Stay clear of fan blades, belts, pulleys, and other moving parts that can cause personal injury and/or property damage.
3. Check the polarity of the battery posts. A POSITIVE (+) battery post usually has a larger diameter than a NEGATIVE (-) battery post.
4. To reduce explosion risk, never connect both Battery Charger DC output clamps directly to the battery.

***Symbology***

	Double Insulated
	Canadian Standards Association
	Underwriters Laboratories, Inc.
<b>V</b> ~	Volts Alternating Current
<b>A</b>	Amperes
n <sup>o</sup> xxxx/min.	No Load Revolutions per Minute (RPM)



**WARNING!** The warnings, precautions, and instructions discussed in this manual cannot cover all possible conditions and situations that may occur. The operator must understand that common sense and caution are factors which cannot be built into this product, but must be supplied by the operator.

### Unpacking

When unpacking the Automatic Battery Charger, check to make sure parts on page 11 are included. If any parts are missing or broken, please call **HARBOR FREIGHT TOOLS** at **1-800-444-3353**.

### Operation

1. **Determine which post of the battery is grounded (connected) to the chassis of the vehicle.**

If the NEGATIVE (–) post is grounded to the chassis (**as in most vehicles**), attach the POSITIVE (+) DC output clamp to the POSITIVE (+) battery post and connect the NEGATIVE (–) DC output clamp to a clean, thick, metal area on the vehicle chassis or engine block away from the battery. Do not connect the NEGATIVE (–) DC output clamp to the carburetor, fuel lines, or thin sheet metal body parts.

If the POSITIVE (+) post is grounded to the chassis, attach the NEGATIVE (–) DC output clamp to the NEGATIVE (–) battery post and connect the POSITIVE (+) DC output clamp to a clean, thick, metal area on the vehicle chassis or engine block away from the battery. Do not connect the POSITIVE (+) DC output clamp to the carburetor, fuel lines, or thin sheet metal body parts.

2. **When disconnecting the Battery Charge from the battery, turn all switches of the Battery Charger to their “OFF” position.** Unplug the AC input power cord from its electrical outlet. Remove the DC output clamp from the vehicle chassis. Then, remove the DC output clamp from the battery.

To Reduce Risk Of Sparking - When The Battery Is Outside The Vehicle:

1. **Check the polarity of the battery posts. A POSITIVE (+) battery post usually has a larger diameter than a NEGATIVE (–) battery post.**
2. **Attach at least a 24 inch long, 6 gauge (AWG), insulated battery cable to the NEGATIVE (–) battery post-see Figure A below.**
3. **Connect the POSITIVE (+) DC output clamp to the POSITIVE (+) post of the battery.**
4. **Position yourself and the free end of the 24 inch long, 6 gauge (AWG), insulated battery cable as far away from the battery as possible.** Connect the NEGATIVE (–) DC output clamp to the free end of the cable. Do not face the battery when making this final connection. **(See Figure A.)**

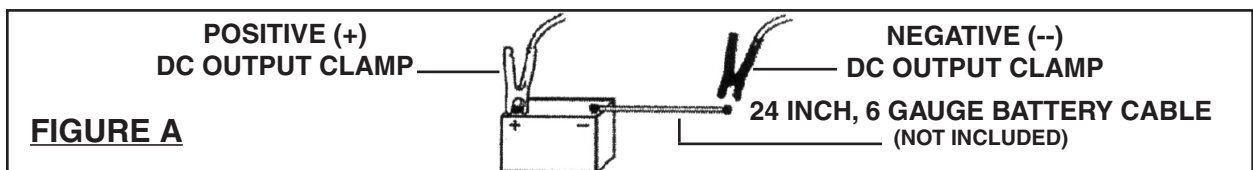

**Note:** The monitoring voltage of the Battery Charger is 10.5V; if the voltage is below 10.5V, the Battery Charger will not work. A battery must be properly connected to the charger to allow it to work. For best results, the capacity of the battery should be below 24 Ah.

### Operation (cont'd)

1. Place the Battery Charger on a stable, flat surface.
2. Connect the Red Charging Clamp (15) to the positive (+) terminal of the battery (if the Negative [-] post is grounded to the chassis, as in most vehicles) -refer to specific guidelines on page 9.
3. Connect the Black Charging Clamp (15) to the appropriate site, depending on the specific usage as outlined on page 9.
4. Plug the Input Power Cord (14) into the nearest 115V, grounded, electrical outlet. **The Charging Indication Light (B) will go on when the battery is charging**-see below.
5. **If the Reverse Polarity Indication Light (A) goes on, it indicates that an incorrect hookup has occurred/connections are reversed** (refer to the clamping instructions on page 9)- see below.  
**The green Full Charge Indication Light (C) signals that the battery is fully charged.** The Battery Charger will put out a trickle charge to maintain the existing charge on the battery -see below.

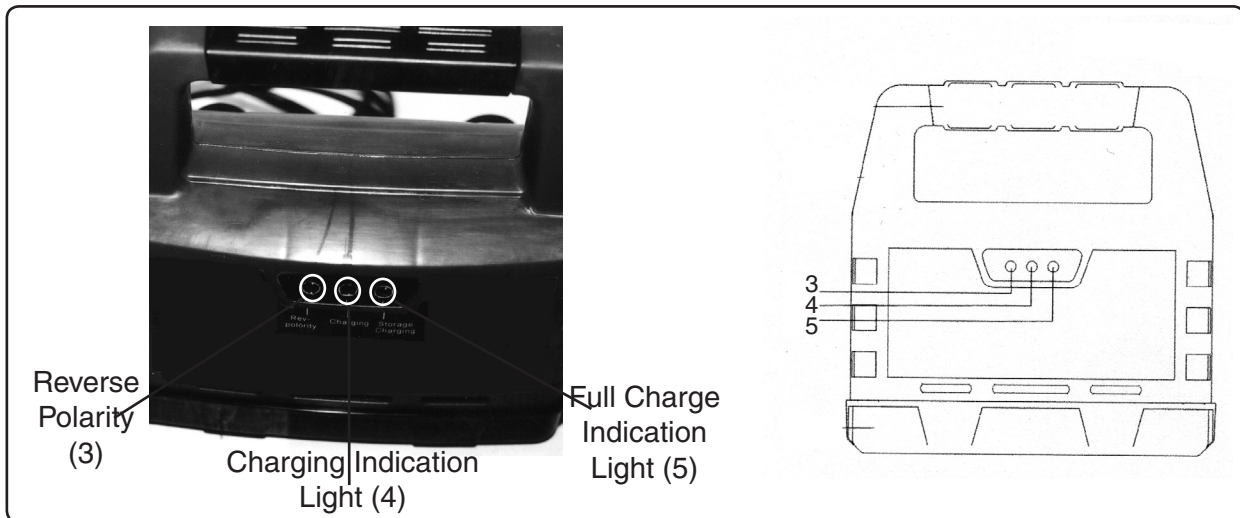

6. Leave the Automatic Battery Charger plugged in to the nearest outlet and attached to the battery until the battery is to be used. Then unplug and remove the Battery Charger.
7. **Disconnect the Charging Clamps (15) in the following order: Remove the Charging Clamp (15) from the chassis, then remove the DC output clamp from the battery.** (Refer to guidelines on page 9.)
8. The Battery Charger has two Storage Posts (7) on the side opposite the LED lights. Wrap all cords around the two Posts (7).

### **Inspection, Maintenance and Cleaning**

1. Before each use inspect the general condition of the Battery Charger. Check for cracked or broken parts, damaged power cords, clamps, and any other condition that may affect the safe operation of the Battery Charger.
2. With a dry cloth, remove any oil and residue from the Battery Charger after each use. Do not clean with flammable or corrosive liquids.
3. Store in a secure, safe and dry location. Store in a location that can be locked and that is out of the reach of children.

### Parts List

Part #	Description	Quantity	Part #	Description	Quantity
1	Front Housing Cover	1	11	Transformer	1
2	Back Housing Cover	1	12	Main Circuit Board	1
3	Handle Top Cover	1	13	Indication Light	1
4	Handle Bottom Cover	1		Circuit Board	1
5	Handle Sleeve	1	14	Input Power Cord	1
6	PVC Base	1	15	Charging Clamp	2
7	Storage Posts	2	16	Tap Screw 2.5 X 10	2
8	Cable Clip 1	1	17	Tap Screw 3 X 12	9
9	Cable Clip 2	1			

### Assembly Diagram

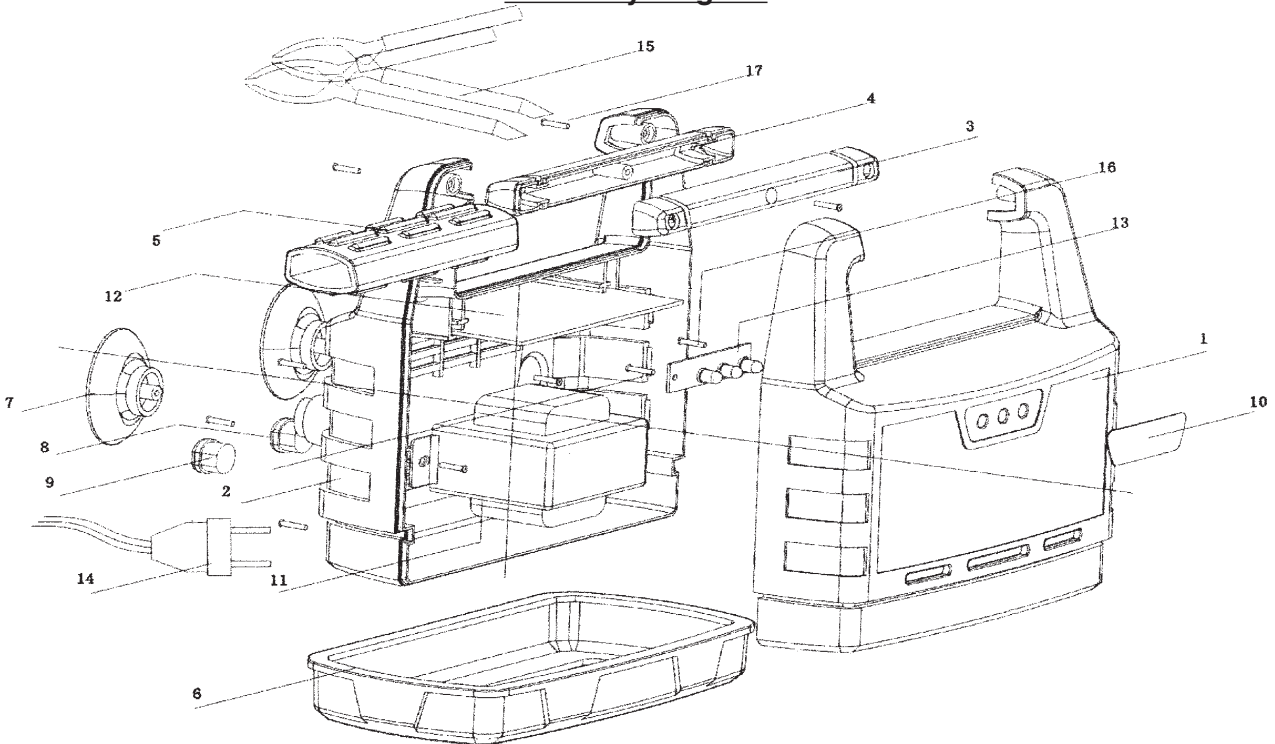

Note: Some parts are listed and shown for illustration purposes only and are not available individually as replacement parts.

**PLEASE READ THE FOLLOWING CAREFULLY**

**THE MANUFACTURER AND/OR DISTRIBUTOR HAS PROVIDED THE PARTS DIAGRAM IN THIS MANUAL AS A REFERENCE TOOL ONLY. NEITHER THE MANUFACTURER NOR DISTRIBUTOR MAKES ANY REPRESENTATION OR WARRANTY OF ANY KIND TO THE BUYER THAT HE OR SHE IS QUALIFIED TO MAKE ANY REPAIRS TO THE PRODUCT OR THAT HE OR SHE IS QUALIFIED TO REPLACE ANY PARTS OF THE PRODUCT. IN FACT, THE MANUFACTURER AND/OR DISTRIBUTOR EXPRESSLY STATES THAT ALL REPAIRS AND PARTS REPLACEMENTS SHOULD BE UNDERTAKEN BY CERTIFIED AND LICENSED TECHNICIANS AND NOT BY THE BUYER. THE BUYER ASSUMES ALL RISK AND LIABILITY ARISING OUT OF HIS OR HER REPAIRS TO THE ORIGINAL PRODUCT OR REPLACEMENT PARTS THERETO, OR ARISING OUT OF HIS OR HER INSTALLATION OF REPLACEMENT PARTS THERETO.**